



INTEGRATED RS4 AIR PURIFICATION SYSTEMS

An Integrated Air Purification System For Maximum Airborne Contaminant Control

- Electronic Polarized Media for control of ultrafine particles.
- Activated Carbon Matrix for odor and gas phase contaminant control.
- Ultraviolet Germicidal System for control of airborne viruses, biologicals, germs and gases.
- 1400 CFM, Right Angle left or right.
- Flow-thru side to side or top to bottom.
- One model, easy field conversion.
- Adjustable 24-gauge flanges for multiple duct sizes.
- Knockouts for Models 407 high output UVC system.
- Heavy Duty 16–20-gauge steel cabinet.



FOR FINE PARTICLES

Dynamic Polarized Media Electronic Air Cleaner

Delivering MERV 13 performance in a recirc application, Dynamic Polarized Media Electronic Air Cleaners provide ultra-efficient particulate removal. The Dynamic Polarized Media Air Cleaner removes dangerous submicron particles and other contaminants that other filters miss, including bacteria, odors, and smoke.

FOR GAS PHASE CONTAMINANTS

Dynamic Activated Carbon Matrix

The Dynamic Activated Carbon Matrix (ACM) brings the power of industrial strength activated carbon to your home. The Dynamic ACM uses advanced composites and extrusion technologies to provide the effectiveness of an industrial-strength activated carbon system. Dynamic ACM is suitable for high airflow, high temperatures, and high humidity.

FOR GERMS AND VIRUSES

Dynamic Series2 UVC Germicidal Lamp

UVC efficiency is a function of lamp microwatt output. The Dynamic 407H-16 and 407H-16-O3 (with activated Oxygen) Series2 UVC systems offer 180 microwatts and a dual lamp configuration for one of the highest output UVC systems available today.

AIR CLEANER & CARBON

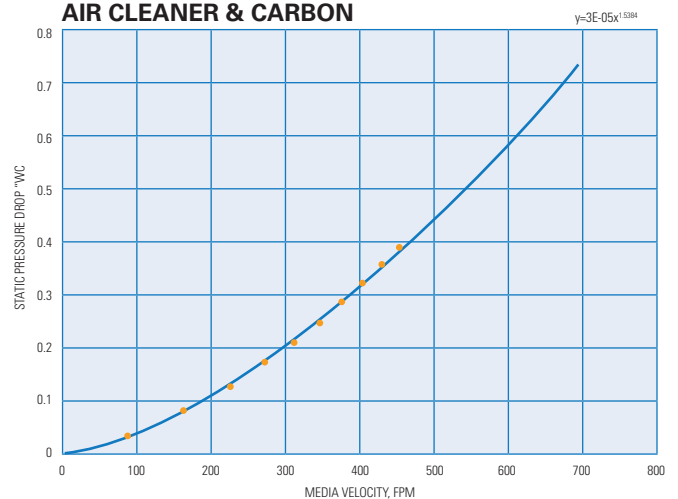

Unit Weight EAC only	14 lbs (6.35 kg)
Unit Weight EAC + Carbon	18 lbs (8.2 kg)
Cabinet Dimensions	16-1/4" W x 25" H x 27" D (41.3 cm x 63.5 cm x 68.6 cm)
Adjustable Top (or bottom) Flange	11" x 24" (28 cm x 61 cm) 12" x 24" (30.5 cm x 61 cm) 13" x 24" (33 cm x 61 cm)
Adjustable Side Flange	14" x 24" (35.5 cm x 61 cm) 15" x 24" (38 cm x 61 cm) 16" x 24" (41 cm x 61 cm) 17" x 24" (43 cm x 61 cm) 18" x 24" (46 cm x 61 cm) 19" x 24" (48 cm x 61 cm) 20" x 24" (51 cm x 61 cm)

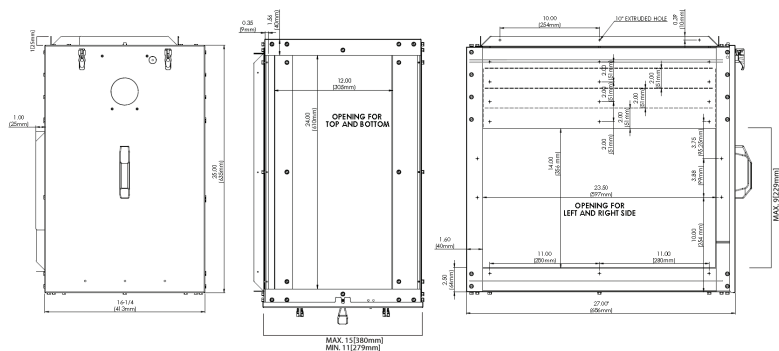

Specifications for RS4 Air Purification System

1.0 General: The air cleaner shall be a one-inch (nominal) electronically enhanced, polarized media air cleaner.

1.1 Non-Ionizing, polarized media air cleaners:

1.1.1 Certifications: The air cleaner shall be tested and meet CSA Standard C22.2 No. 187-M19986, and UL Standard 867 and UL Standard 2998 for electrostatic air cleaners.

1.1.2 Operation: The air cleaner shall have an active electrostatic field that polarizes a dielectric media. It shall not ionize airborne particles or produce ozone.

1.1.3 Performance: The air cleaner shall be able to remove 97% of the airborne particulates 0.3µm and greater in a re-circulating system. Pressure drop across the air cleaner will be no more than 0.2" w.g. @300fpm.

1.1.4 Construction: The air cleaner box shall be 16-20 gauge steel. The construction of the air cleaner frame and screens shall be aluminum and galvanized steel. The electronic power supply (power head) shall impart a high DC voltage to the center screen. The air cleaner frame shall be hinged so as to allow easy access to the media pad for replacement.

1.1.5 Electronics: The power head shall be capable of converting 24VAC to 7 kV (DC) and draw no more than two watts of power. The power head shall be insulated from the air cleaner frame and shall transmit the 7 kV (DC) to the center screen of the media pad through a titanium filament.

1.1.6 Power Supply: The 24VAC power supply must be a UL or CSA certified transformer, class "2"-type, which shall permit one side of the secondary output (24V) to be attached to ground.

1.1.7 Filter Media: Replaceable filter media shall be individual, disposable glass fiber "pillows"; which shall consist of two ply of fiberglass with a conductive center screen of metal of activated carbon mesh. This center screen shall be permanently enclosed between the two pieces of fiberglass and shall be disposed of when the media pad is changed. The glass fiber media must be fabricated from a constant filament so that any shed fibers are not respirable. The glass fiber must have a minimum of a class "2" fire rating.

1.2 Activated Carbon Matrix System (Optional):

1.2.1 Certifications: The material shall have been tested and meet ASTM International Standard D664603 for removal of Hydrogen Sulfide.

1.2.2 Performance: The material shall be suitable for damp conditions up to 99% RH. It shall be dust-free under normal operation. It shall have a minimum crush strength of 600 psi. It will have removal capacities (by weight) of 40% for Hydrogen Sulfide, 15% for Sulfur Dioxide, 13% for Xylene and 9% for Toluene.

1.2.3 Construction: Carbon filtration media is housed in either a plastic or metallic frame & is available in nominal depths of one, two, four, and six inches as standard. Modules are designed to fit in a side-access filter track or a Type 8 filter frame, and are available with or without a header.

1.2.4 Filter Media: In composition, the material is composed of a carbon/ceramic mixture that is extruded and then baked to produce parts a variable number of channels (cells) through which air can pass. The cells per square inch (CPSI) can vary from 16 to 400 although the weight percent of the carbon shall be kept constant.

1.3 Germicidal UVC Emitter (Optional):

1.3.1 Certifications: The unit shall be tested and meet UL Standards 1598 and CSA Standard C22.2 No. 250.0-00.

1.3.2 Performance: The UVC lamp shall be a high output H lamp with output of 180 microwatts in the 250-260 nm range.

1.3.3 Installation: The UVC lamp shall be permanently mounted to the RS4 access door. All access shall be labeled in accordance with ISHA regulations for UVC devices.

1.3.4 Electrical: Input voltage to the units shall be 120vac. The unit shall draw a peak of .3 amps and shall be equipped with an interlock switch so that power will be cut to the unit if the RS4 access door is removed from the system.

